

**ANDHRA PRADESH EDUCATION & WELFARE  
INFRASTRUCTURE DEVELOPMENT CORPORATION**



**AGREEMENT**

**Name of the work :** Procurement of Double Skin Powder Coated GI openable / casement single rebate Windows with 5 mm thick polycarbonate sheet size of window 1.50 M x 1.35 M (three openable shutters) including supply and fixing to the Government Schools (Educational Institutions) of East Godavari, Konaseema, West Godavari, Eluru, Krishna, NTR, Guntur and Palnadu (8) Districts as Package II under MANABADI NADU-NEDU Phase II

**Estimate Cost:** Rs. 78.25 Crores

**Name of the Contractor:** M/s Decomet Industries Private Limited,  
Sy. No. 217, 218 and 687, Ayodhya X Road,  
Kandlakoya (v), Gundlapochampally (M),  
Medchal – Malkajgiri District,  
Hyderabad – 501 401.

**O/o THE MANAGING DIRECTOR,  
APEWIDC, Vaddeswaram (V)Tadepally (M), Guntur**

## Annexure-A

## SCHEDULE-A

S.No	Qty in sqm	Item Description	Rate per Sqm	Amount Rs.
1	53293.95	<p>Supply and fixing of Double Skin powder coated GI openable/casement single rebate Windows with 5mm thick Polycarbonate sheet SIZE OF WINDOW 1.50 M X 1.35M (three openable shutters) Providing and fixing of powder coated Openable/Casement GI Window of size 1.50mx1.35m (three openable shutters). Window frame having two horizontals &amp; four verticals (Base steel as per IS513 of 0.60mm thick galvanized as per IS 277 with Zinc of 120 GSM), powder coated paint of 60-65microns(DFT) thick and section for double Skin outer frame of 80 mm x 65 mm x 0.6mm thick including architrave of 20mm, centre mullions of 80mm x 60mm x 0.6mm thick and section for Double Skin shutter of 52mm x25 mm x 0.6 mm thick, outer frame and mullions to have rebate for glazed shutter and the sections cut to length metre joined with corner bracket, center mullion fixed with mullion cap, shutter with 5mm thick Polycarbonate Solid clear UV resistant sheet of reputed make ( UV stabilized, transparent &amp; solid section ) with EPDM rubber gaskets including fixing the frames in concrete/masonry wall by means of self-expanding screws, Including 10mm Square guard bars with 14Nos horizontals &amp; two verticals, ' the window shutter shall be provided with suitable size U shaped EDPM gasket to hold the Polycarbonate sheet, including infill material of polyurethane foam (PUF) and all fixers like 100mm long SS handle -3 Nos, 125mm long SS tower bolts-6Nos, 75mm long SS ball bearing butt Hinges-9Nos, 200mm long SS latch type window stopper -3Nos (all fixers should be stainless steel 304 grade) including all stiffeners ,supporting plates, SS 304 screws, Nylon caps, EPDM rubber gasket etc., complete for finished item of work. and including cost &amp; conveyance of all materials and all labour charges like loading, unloading, and fixing of powder coated Galvanized Steel Window etc., complete for finished item of work.</p> <p><b>Window Frame:</b> Frame having four verticals &amp; two horizontals, around frame section of size:80mmx65mm x 0.6mm thick including architrave of 20mm and center mullions section of size; 80mmx60mm x0.6mm thick. (2Nos), with single rebate.</p> <p><b>Shutters (3 Nos):</b> Shutter section of size 52mm x25 mm x 0.6 mm thick with 5mm thick Polycarbonate Solid Clear UV resistant sheet of reputed make (UV stabilized, transparent &amp; solid section)</p> <p><b>Infill Material:</b> polyurethane foam (PUF)</p> <p><b>Grill:</b> Grill having 14 Nos of 10mm sq rods (horizontals) and 2Nos of 10mm Sq rods (verticals), 10mm sq rods should be inserted into outer frame &amp; center mullions as directed by the Engineering in charge,</p>	15068.46	80,30,57,753.81 (Rupees Eighty Crores Thirty Lakhs Fifty Seven Thousand Seven Hundred and Fifty Three and Paise Eighty One Only)

For DECOMET INDUSTRIES PVT. LTD.

K. S. [Signature]  
 Authorized Signature of the  
 Firm/Company.

Director

[Signature]  
 23/5/23

Note; 4 Nos of 10mm sq rods should be inserted into outer frame & centre mullions (As per drawing shown below).

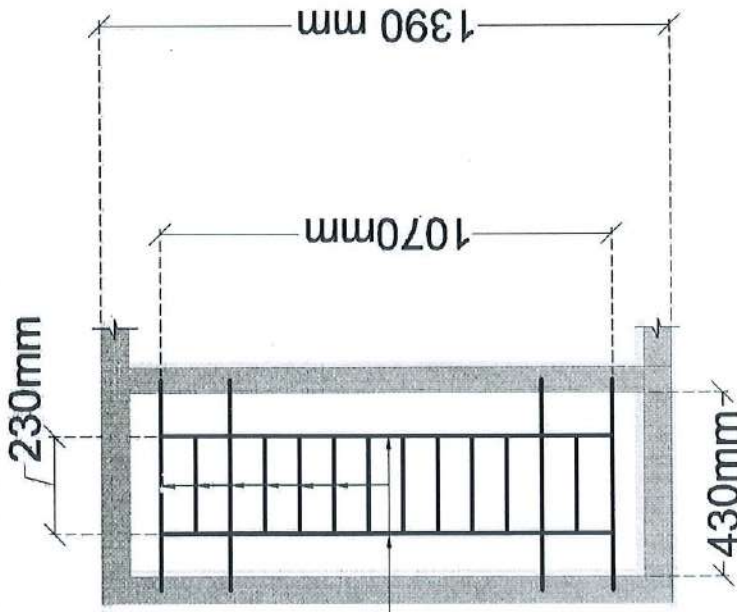

14 No's Horizontals &  
2 No's Verticals of  
10mm square rods  
(Edge should be in  
front elevation)

Fixers: 100mm long SS handle -3 Nos, 125mm long SS tower bolts-6 Nos, 75mm long SS ball bearing butt Hinges  
9 Nos, 200mm long SS latch type window stopper -3 Nos

Note ; all fixers should be stainless steel 304

Rear Face of Window size : 1.50 MX 1.35 M

Front face of Window size : 1.54 MX 1.39 M ( including Architrave)

For Authorized Signature of the  
Firm/Company INDUSTRIES PVT. LTD.

*Sh. K. K. K.*

Director

*Sh. K. K. K.*

*A. V.*

	<p>The Window outer Frame, Mullions and Shutter frame shall be Closed Box profiles, using roll forming procedures . Suitable lock-seam joints shall be provided with proper stitching procedures. The process shall be carried out cold. No welding, no soldering, no screws, no bolt-nuts.</p> <p>Infill material of Polyurethane (PUF) shall be provided in Window frame Box Profile, Mullion Box Profile and Shutter Box Profile. Injected Polyurethane Foam ( PUF) procedure shall be adopted. Density of PU-Foam shall be 32 to 36 kg/m<sup>3</sup>.</p> <p>The price/ rate per sqm is for the dimensional area of the outer to outer of window frame only i.e., Window opening area only (1.50 M X 1.35 M), excluding architrave. The rate will be measured, billed and paid for the area of 2.025 Sqm i.e. 1.50 mtrs X 1.35 mtrs .</p> <p><b>Weather Gasket for outer frame &amp; Mullions:</b> Groove in Frame and Mullion shall be provided to hold EDPM Gasket so that the shutters will not hit/rest on the frame and Mullion when the shutters are closed. The window shutter shall rest on the EDPM Gasket when closed. And to make the window as weather resistant.</p> <p>In the shutter suitable size u shaped EDPM gasket shall be provided to hold the Poly carbonate sheet firmly.</p> <p>Shall confirm to the BIS codes: -IS 1038:1983: Steel doors and windows, IS 4351:2003: Steel Door and window shutters, IS 13871:1993: Powder coating, IS 277: Galvanized Steel Sheets, IS 513: Cold reduced low carbon steel sheets IS ; 1081: Fixing and glazing of Steel Doors and Windows, IS 14443 (1997): Polycarbonate sheets, IS12436:1988 for PUF and all other relevant codes of BIS.</p> <p><i>“Nadu – Nedu 2023” Logo shall be embossed and painted on the top of the Window frame in the middle, the size of logo shall be such that it is clearly visible.</i></p> <p>This Item shall carry a warranty period of 5 (Five) Years from the date of completion of supply and fixing.</p>	
	<p><b>Grand Total (Including GST and all other Taxes etc.,)</b></p>	<p><b>Rs.80,30,57,753.81</b> (Rupees Eighty Crores Thirty Lakhs Fifty Seven Thousand Seven Hundred and Fifty Three and Paise Eighty One Only)</p>

For DECCOMET INDUSTRIES PVT. LTD.  
Authorized Signature of the  
Firm/Company

Director

Managing Director  
APEWIDC, Vijayawada

*(Handwritten signature)*

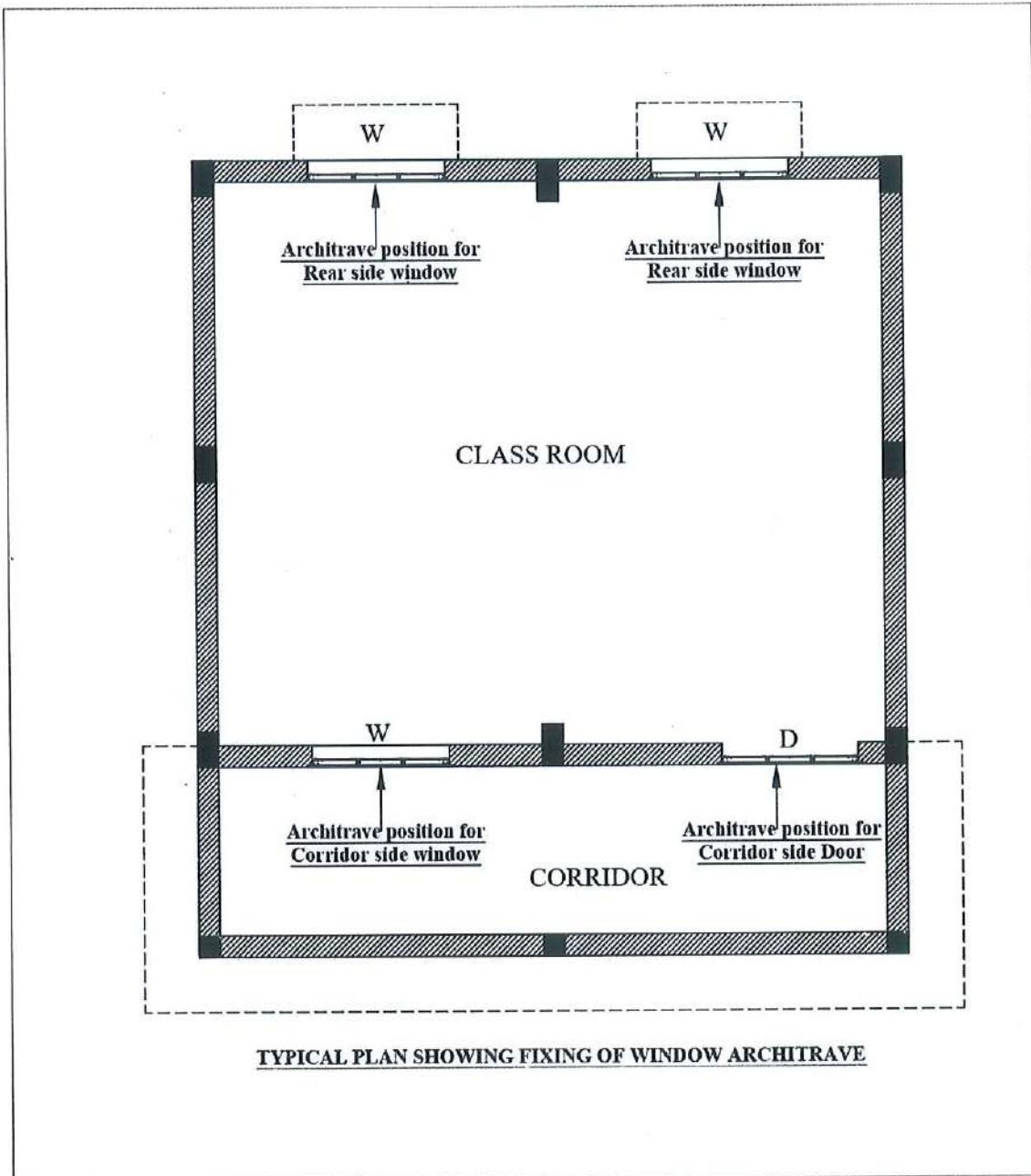

For DECQMET INDUSTRIES PVT. LTD.

*H. S. S.*  
 Authorized Signature of the Director  
 Firm/Company

*GS*  
 Managing Director  
 APEWIDC, Vijayawada

*A* *W* *3/5/23*

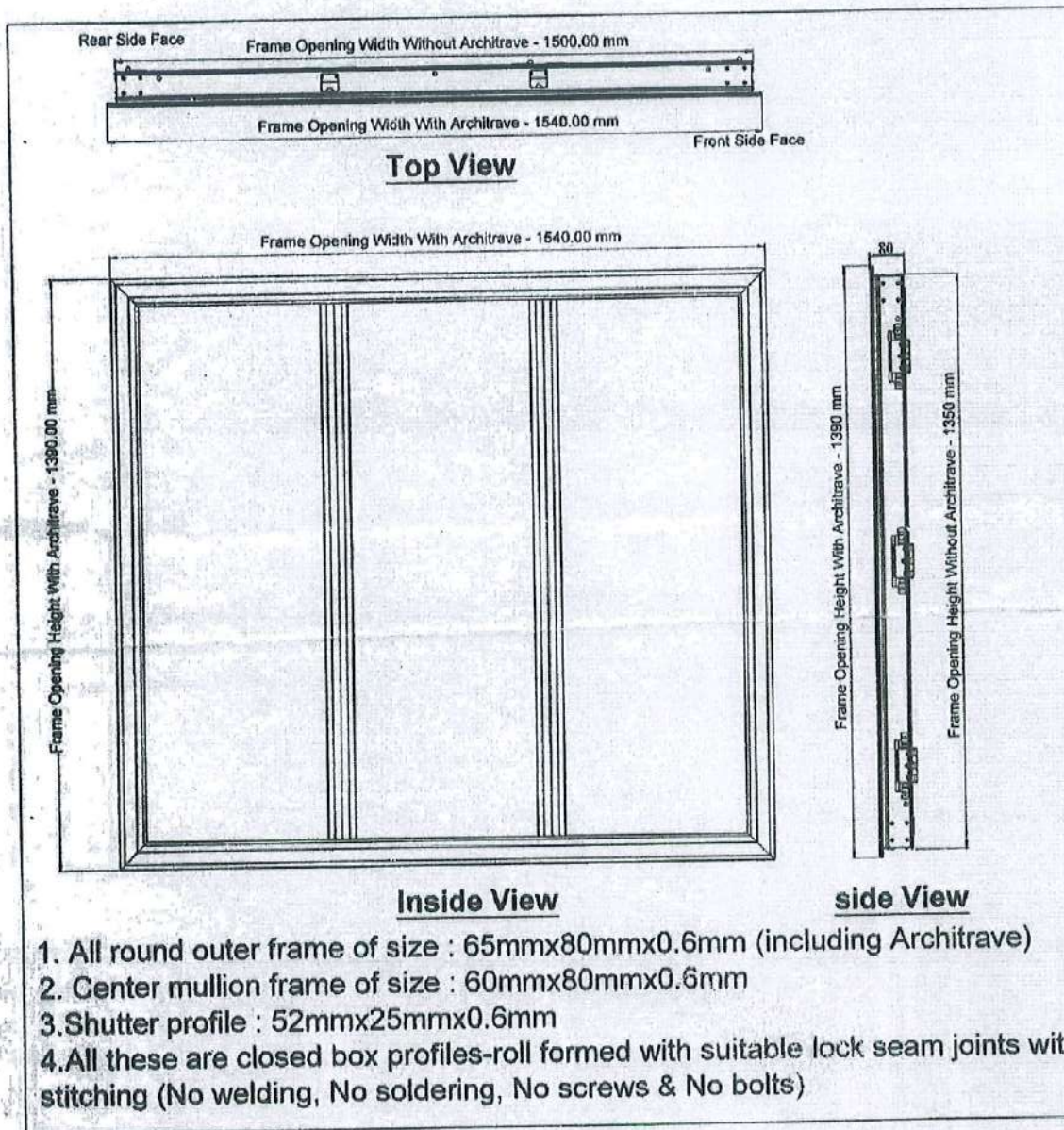

For DECOMET INDUSTRIES PVT. LTD.

*[Signature]*  
 Authorized Signature of the  
 Firm/Company      Director

*[Signature]*  
 Managing Director  
 APEWIDC, Vijayawada

*A*      *w*      *4/3/23*

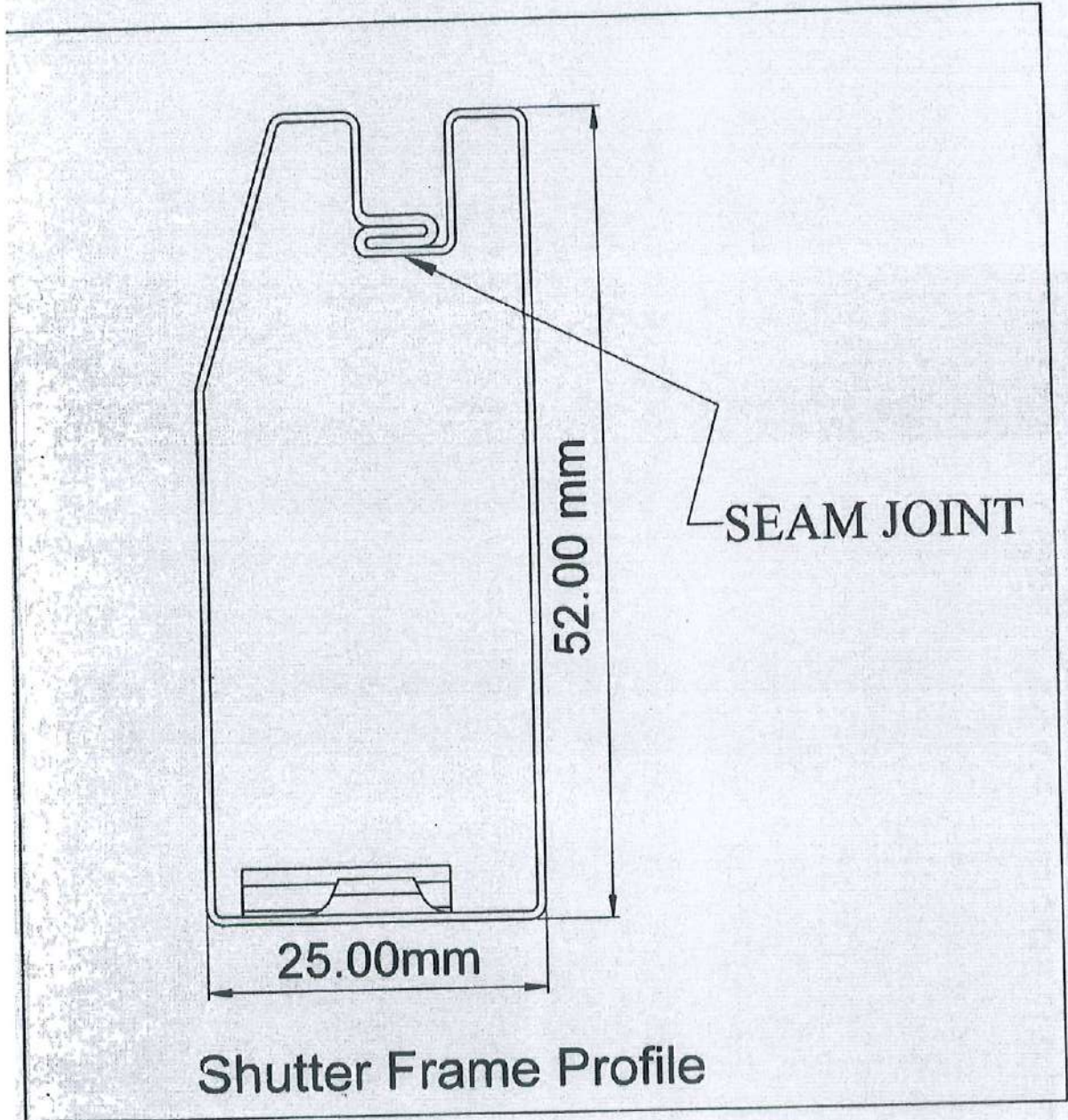

For DECOMET INDUSTRIES PVT. LTD.

*[Signature]*  
 Authorized Signature of the  
 Firm/Company Director

*[Signature]*  
 Managing Director  
 APEWIDC, Vijayawada  
*[Handwritten marks]*

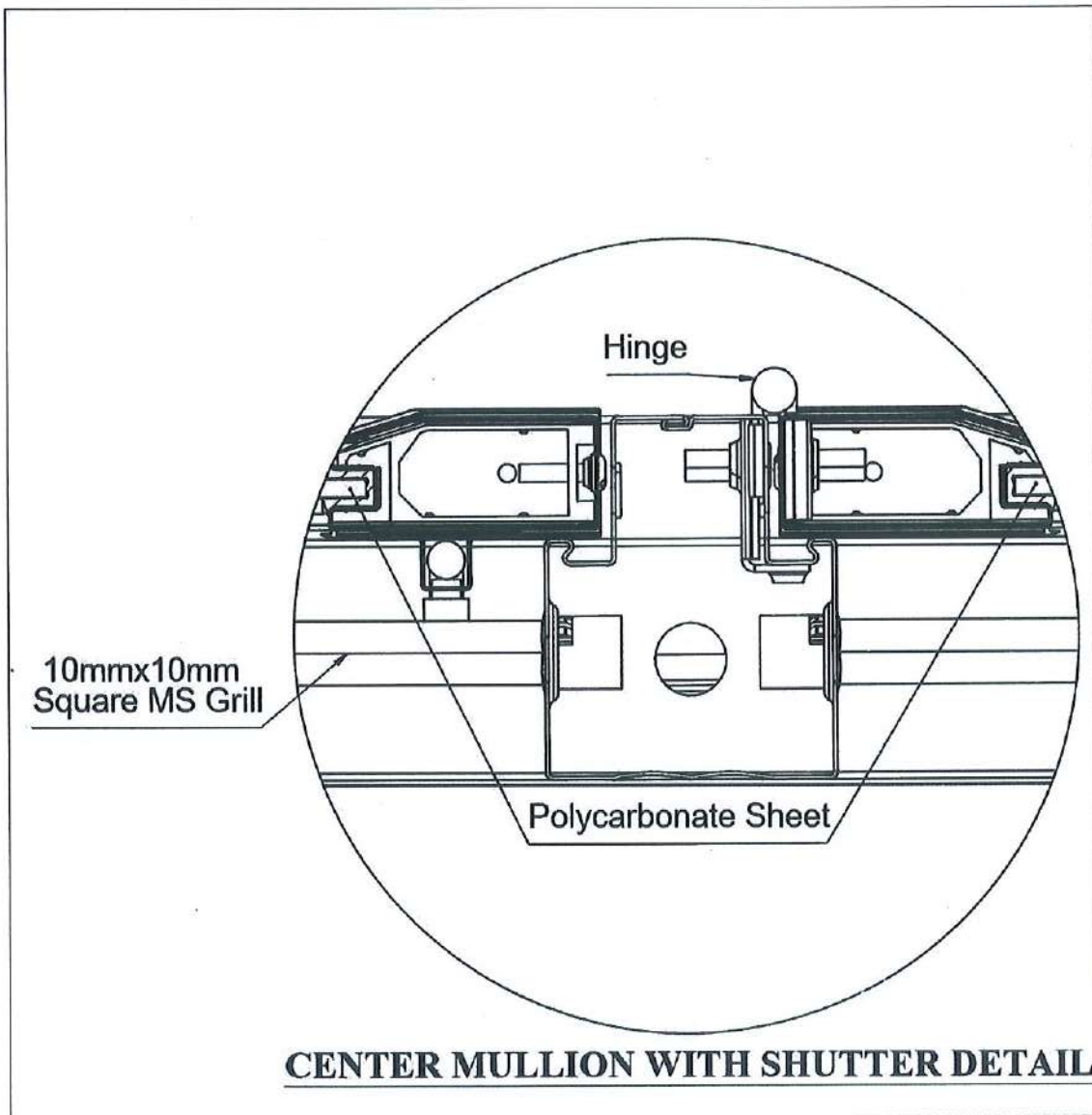

For DECQMET INDUSTRIES PVT. LTD.

*K. Sankar*  
 Authorized Signature of the  
 Firm/Company Director

27

*4 w 4/3/15/23*

*[Signature]*  
 Managing Director  
 APEWIDC, Vijayawada



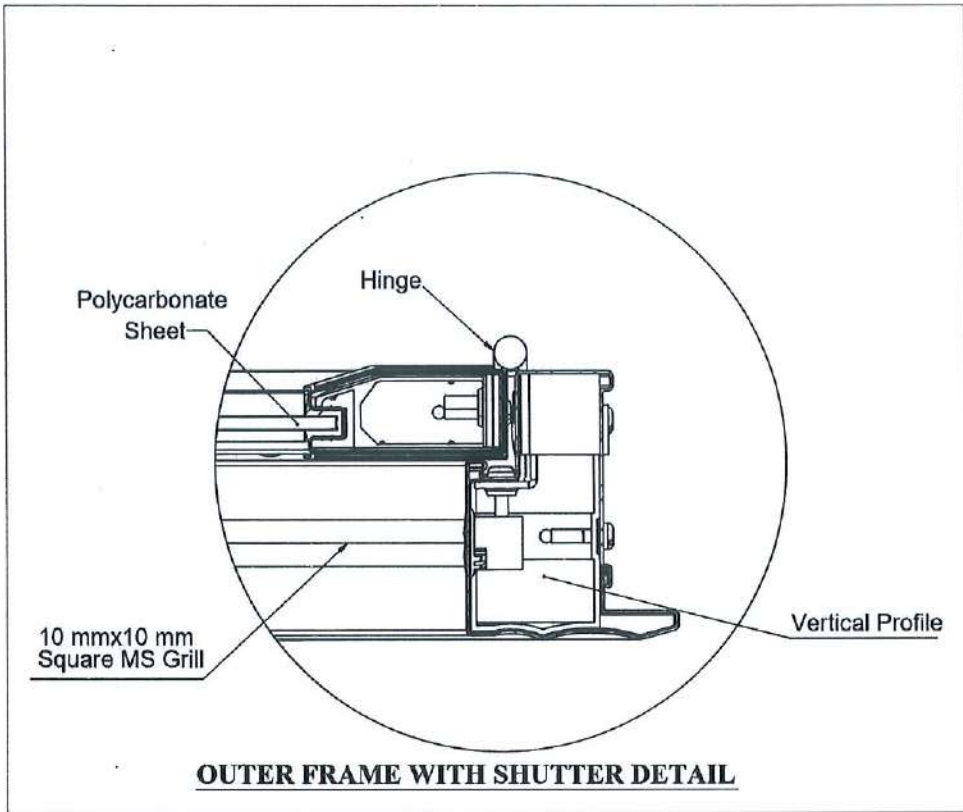

For DECQMET INDUSTRIES PVT. LTD.

*Sh. Sankar C*  
Authorized Signature of the  
Firm/Company

Director

28

*A W* *3/5/23*

*SP*  
Managing Director  
APEWIDC, Vijayawada

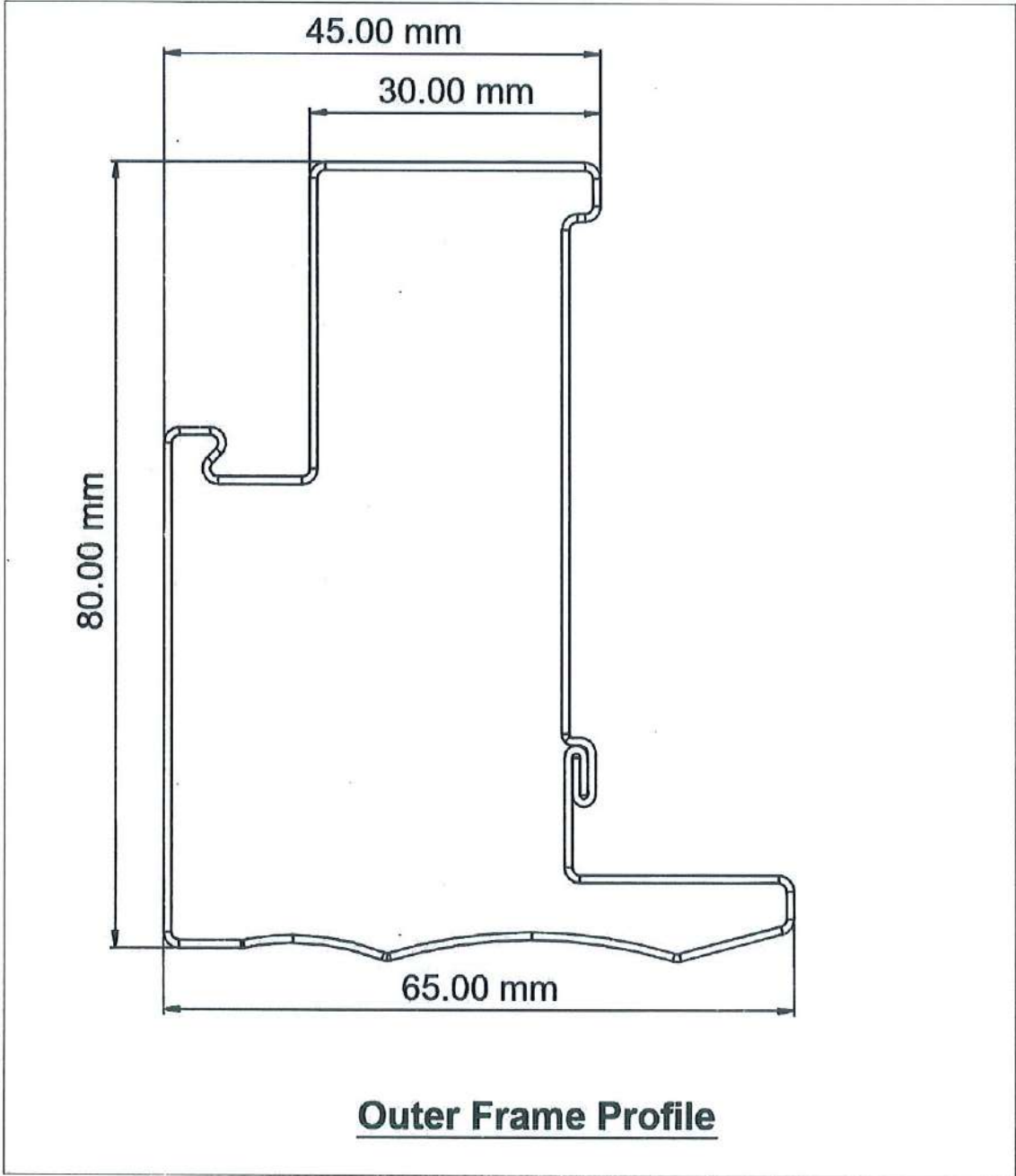

**Outer Frame Profile**

For DECOMET INDUSTRIES PVT. LTD.

*h. s. s.*  
Authorized Signature of the  
Firm/Company

Director

*g.s.*  
Managing Director  
APEWIDC, Vijayawada

*A* *u* *3/5/23*

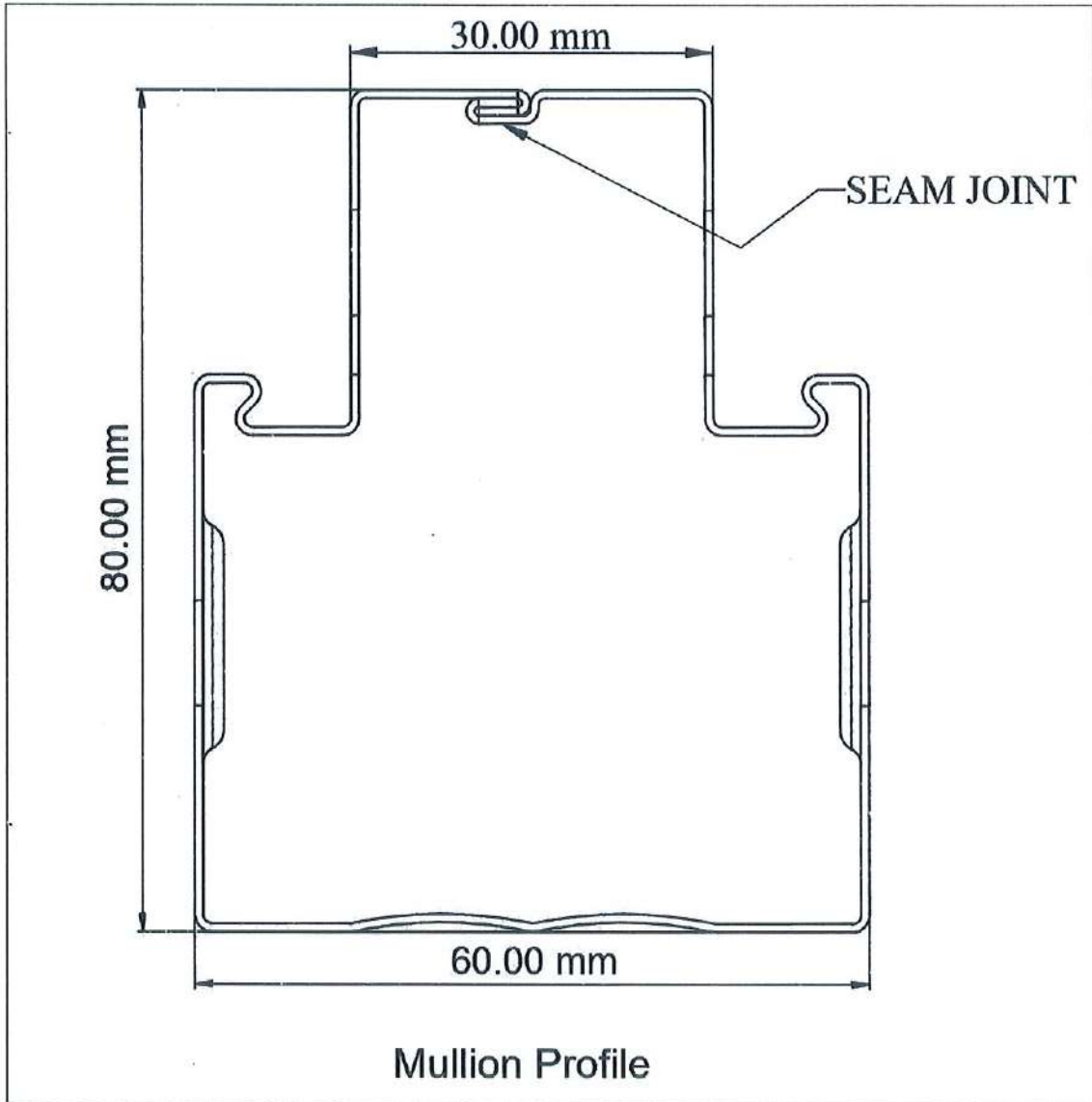

For DECOMET INDUSTRIES PVT. LTD.

*[Handwritten Signature]*

Authorized Signature of the Firm/Company

Director

30

*[Handwritten Signature]*  
 4/3/5  
 23

*[Handwritten Signature]*  
 Managing Director  
 APEWIDC, Vijayawada